

# PROTEGO® Tank Accessories and Special Equipment



## Section 8

Section 8





Tanks in tank farms and large vessels not only need to be equipped with flame arresters or pressure and vacuum valves, but they also need special equipment that meets the same high requirements to operate safely.

### Special Valves with Safety Functions

For emergency shut-off or extraordinary operating conditions, it is necessary to provide internal safety valves to quickly prevent product leakage after a pipe burst.

### Gauging and Sampling Equipment

**Gauge and sampling hatches allow the use of gauging and sampling devices** in the tank. For horizontal tanks, deflagration-proof gauging pipes are available.

For sampling and local venting of tanks that store flammable liquids, PROTEGO® has designed special sampling and air bleed valves with flame arrester elements.

Explosion-proof floor drains for helicopter landing pads safely release flammable liquids (e.g., kerosene) into collecting containers. There is no flame transmission if an outside ignition source ignites the potentially explosive atmosphere.

### Floating Suction Units and Skimming Systems

PROTEGO® SA/S floating suction units are used in storage tanks with very high purity requirements of the substances, e.g., aviation or fossil fuels.

Fixed roof tanks that store liquids with different densities, so-called slop tanks, are fitted with the Floating Skimmer System PROTEGO® SA/DA for separating the phases.

Together with the tank operator or tank builder, we develop the best way to ensure both economical and safe operation.

### Floating Roof Tank Equipment

For floating roof tanks, the **drainage system for the floating roof** must be very precisely designed. Every movement of the floating roof must be considered, and the load on the joints must not affect the free moving space. If there is restricted movement, the system will crack, the pipes will bend, and the joints will be stuck. In order to prevent the water in the system from standing still and freezing, ensure sufficient drain to the lateral tank nozzle. Decades of experience have been incorporated into the trouble-free systems – from the **roof drain valves** to the systems with ball bearing joints or metal hose joints. When the floating roofs are in maintenance position, the completely drained space below the floating roof must be vented through a **lift-actuated vent valve**. When storing flammable liquids in the tank, venting is to be done through flame arresters.

### Special Equipment

Hygroscopic products must be vented with dry air when stored. **Air-drying devices** with dry beads extract moisture from the air.















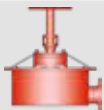
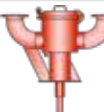

### Selection













The special valves, systems, and devices are designed together with the operator, engineering company, and tank builder. PROTEGO® prepares a quotation based on the detailed system specifications.





PROTEGO® Tank Accessories and Special Equipment

	Type	Size	Description	Page
<b>Floating Suction Unit</b>				
	SA/S		Floating Suction Unit	378 - 379
	SA/DA		Floating Skimmer System	380 - 381
<b>Floating Roof Tank Equipment</b>				
	SE/K	80 - 100 3" - 4"	Floating Roof Drainage System with Metal Hose Joint	382 - 383
	SE/CK	80 - 150 3" - 6"	Floating Roof Drainage System with Swivel Joints	384 - 385
	D/SR D/SR-W	80 - 150 3" - 6"	Roof Drain Valves	386 - 387
	AL/DK AL 200	200 8"	Vent Valve, Lift-actuated	388 - 390
<b>Gauging and Sampling Equipment</b>				
	PF/K PF/TK PS/KF	100 - 200 4" - 8"	Gauge Hatch with flange	392 - 393
	PS/K PS/TK	100 - 200 4" - 8"	Gauge Hatch with welded nozzle	394 - 395
	PU-IIA	25 - 50 1" - 2"	Gauging Pipe, deflagration-proof	 
	PR/0	25 - 150 1" - 6"	Gauging and Sampling Pipe, verifiable	 
	VP/HK with PS/E und PG/H	100 - 150 4" - 6"	Gauging and Sampling Device with accessories	 

	Type	Size	Description	Page
<b>Deflagration proof Special Valves</b>				
	ZE/WU	15 - 25 G½" - G1"	Sampling and Air Bleed Valve, deflagration-proof	396 - 397
	ZE/TK	15 - 25 G½" - G1"	Condensate Drain Valve, deflagration-proof	398 - 399
<b>Air-Drying Devices</b>				
	LA	50 - 150 2" - 6"	Air-Drying Device	 
	LA/V	50 - 150 2" - 6"	Air-Drying Device with Check Valve	 
<b>In-Tank Valve</b>				
	SI/F	50 - 200 2" - 8"	Internal Safety Valve	400 - 401
	NB/AP	→ Section 9		422 - 423
	SI/DP	→ Section 9		424 - 425
	WV/T	→ Section 9		420 - 421



## Floating Suction Unit

PROTEGO® SA/S

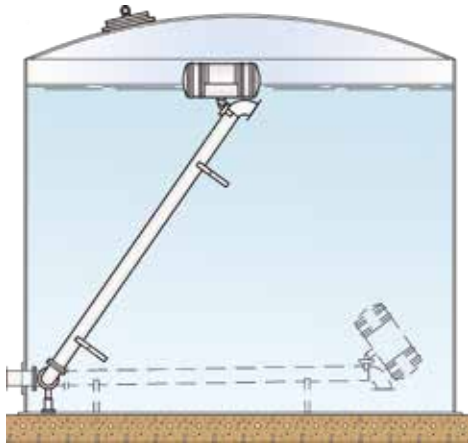

PROTEGO® SA/S for fixed roof tanks

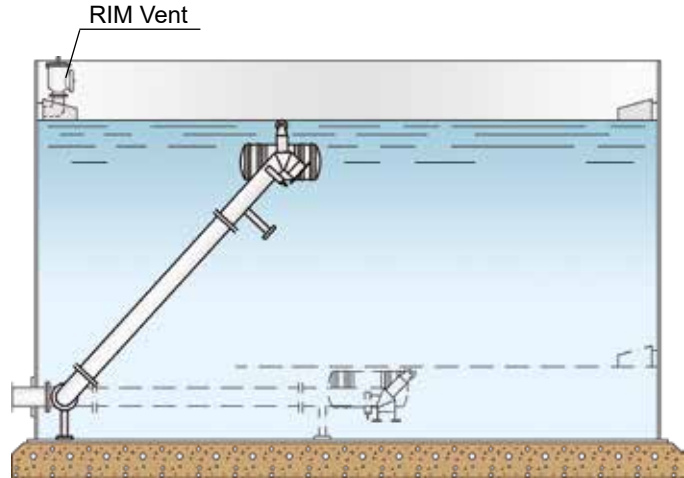

PROTEGO® SA/S for floating roof tanks

### Function and Description

PROTEGO® Floating Suction Units, FSU, are used in storage tanks with very high purity requirements of the substances, e.g., aviation or fossil fuels. They are designed to ensure that product in a storage tank is drawn off just below the surface of the liquid where it is cleanest. This prevents the settled water and residuals at the bottom of the tank from being sucked in.

### Design Types and Specifications

PROTEGO® Floating Suction Units are designed and sized to suit the individual tank specifications and customer requirements.

PROTEGO® Floating Suction Units are designed for long-term operation in full contact with the substances used. We use carbon steel or stainless steel for highly loaded components or aggressive substances.

Sizes are available from 1" to 36" for horizontal or vertical tanks with fixed or floating roofs. Custom designs for unusual stored products are available.

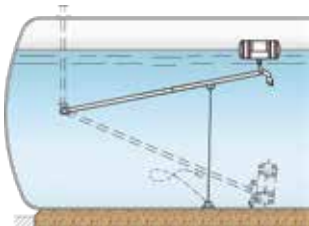

PROTEGO® SA/S for horizontal tanks

### Selection and Design

PROTEGO® Floating Suction Units are the result of extensive experience and are well-conceived solutions for the end-user. This includes easy installation, assembly, and full project documentation with design drawings taking into account tank installations.

Essential for the design of the PROTEGO® Floating Suction Unit is the Heavy Duty Swivel Joint, which is designed to work maintenance-free for many years in full contact with the substances used. This design provides the tank operator with operational reliability, and unforeseen and expensive repairs are prevented.

The Swivel Joints are:

- made of carbon steel or stainless steel;
- lubricated with a maintenance-free lifetime lubrication system; and
- equipped with a double row ball bearing with larger sizes to optimize reliability.

PROTEGO® Floating Suction Units are equipped with a suction opening which prevents a vortex from forming and the suction of air.

Floats are all made exclusively of high-quality stainless steel and are 100 % pressure tested.

Options upon request:

- Sampling pipes
- Function indicator
- Stress calculation due to liquid movement
- On-site support

**PROTEGO® Floating Suction Units are „Made in Germany“ and will provide many years of trouble free tank operation.**

\*Project:  
Location:  
Customer:  
\*End user:  
\*Engineering:

**Tank Main Details**

*Fixed roof tank <input type="checkbox"/>	*Fixed roof tank with internal floating roof <input type="checkbox"/>	
*Floating roof tank <input type="checkbox"/>		
*Horizontal tank <input type="checkbox"/>		
Tank-No.:	*Tank height: mm	*Tank diameter: mm
*Maximum filling height: mm		
*Material design of floating suction unit:		

**Product details**

*Stored product:	
*Product specific density:	
Maximum product temperature: °C	

**Tank details**

*Suction line size: DN	
**Height of connection flange / length of connection piece (inside): mm	
*Manhole size: DN	
Bottom slope: <input type="checkbox"/>	Slope direction:
*Are there any obstructions? (supports, heating pipes, etc.) <input type="checkbox"/>	if <input checked="" type="checkbox"/> - please specify
*Tank drawing / sketch? <input type="checkbox"/>	if <input checked="" type="checkbox"/> - specify request

\*This information must be provided upon request.  
Fill in and  check, if applicable.





## Floating Skimmer System

**PROTEGO® SA/DA**

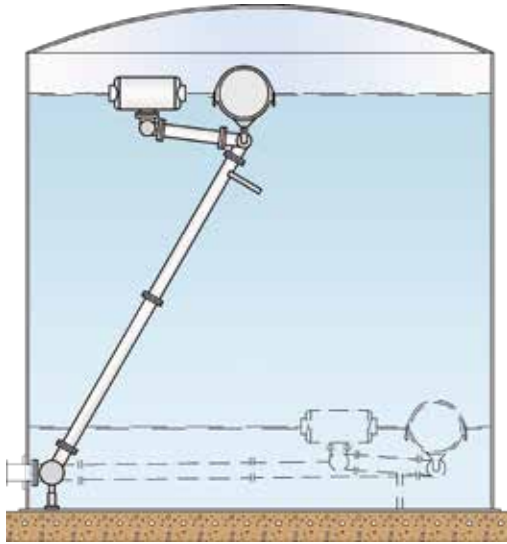

PROTEGO® SA/DA for fixed roof tanks

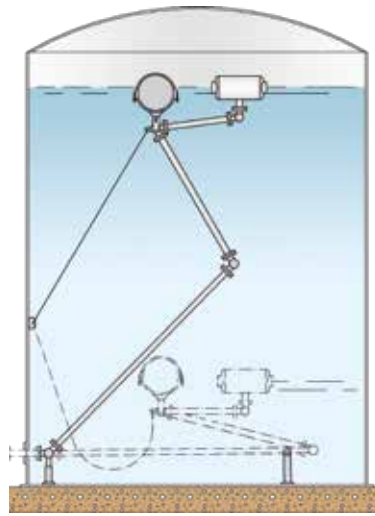

PROTEGO® SA/DA with double-bend for fixed roof tanks

### Function and Description

Fixed roof tanks that store liquids with different densities, so-called slop tanks, are fitted with the Floating Skimmer System PROTEGO® SA/DA for separating the phases. The design of the skimmer is based on the difference of specific densities. They are developed to skim off the lighter product from the surface of the stored substance.

### Design Types and Specifications

PROTEGO® SA/DA Floating Skimmer Systems are designed and sized to suit the individual tank specifications and customer requirements.

PROTEGO® SA/DA Floating Skimmer Systems are designed for long-term operation in full contact with the substances used.

We use carbon steel or stainless steel for highly loaded components or aggressive substances.

Sizes are available from 2" to 6" for tanks with fixed roofs.

### Selection and Design

PROTEGO® Floating Skimmer Systems are the result of extensive experience and are well-conceived solutions for the end-user. This includes easy installation, assembly, and full project documentation with design drawings considering tank installations.

Essential for the design of the PROTEGO® Floating Skimmer Systems is the Heavy Duty Swivel Joint, which is designed to work maintenance-free for many years in full contact with the substances used. This design provides the tank operator with operational reliability, and unforeseen and expensive repairs are prevented.

The Swivel Joints are:

- made of carbon steel or stainless steel;
- lubricated with a maintenance-free lifetime lubrication system; and
- equipped with a double row ball bearing with larger sizes to optimize reliability.

PROTEGO® Floating Skimmer Systems SA/DA are equipped with a fitted with a separate skimmer float, which exclusively performs the function of phase separation. The weight of the entire system is controlled by one or more floats.

Floats are made exclusively of high-quality stainless steel and are 100 % pressure tested.

**PROTEGO® Floating Skimmer Systems are „Made in Germany“ and will provide many years of trouble free tank operation.**



\*Project:  
Location:  
Customer:  
\*End user:  
\*Engineering:

**Tank Main Details**

*Fixed roof tank	<input type="checkbox"/>	
Tank No.:	*Tank height: :	mm
*Maximum filling height:		mm
*Material design of Skimming Systems:		

**Product Details**

*Stored liquid:	Specific density:
*Sucked in liquid:	Specific density:
Maximum product temperature:	°C

**Tank Details**

*Skimming System size: DN	
*Height of connection flange / length of connection piece (inside)	mm
*Manhole size: DN	
Bottom slope:	<input type="checkbox"/>
Slope direction:	
*Are there any obstructions? (supports, heating pipes, etc.)	<input type="checkbox"/>
	if <input checked="" type="checkbox"/> - please specify
*Tank drawing / sketch	<input type="checkbox"/>
	if <input checked="" type="checkbox"/> - specify request

\* This information must be provided upon request.  
Fill in and  check, if applicable.



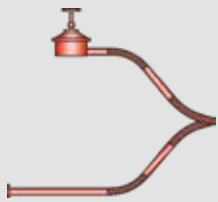

## Floating Roof Drainage System with Metal Hose Joints

PROTEGO® SE/K

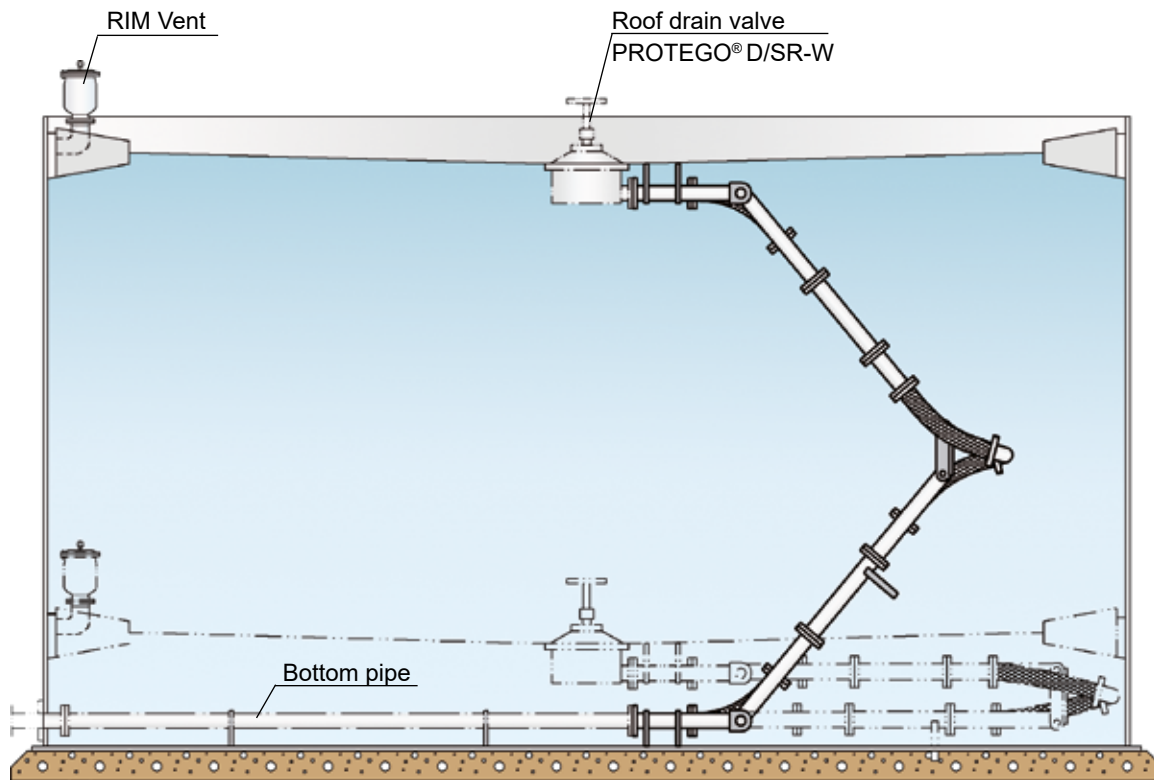

### Function and Description

Floating roof tanks require a drainage system that automatically drains the accumulating rainwater from the floating roof. PROTEGO® SE/K is a single-scissor pipe system that works with sturdy shackle joints. The water is drained by pressure-resistant metal hoses installed without tension.

The upper scissor pipe is connected to the roof drain valve, and the lower scissor pipe is connected to the bottom pipe. The water is drained from the tank through the drainage system via the opened roof drain valve.

### Design Types and Specifications

PROTEGO® floating roof drainage systems are designed and sized to suit the individual tank specifications and customer requirements.

PROTEGO® floating roof drainage systems are designed for long-term operation in full contact with the substances used. a long life in service. We use carbon steel or stainless steel for highly loaded components or aggressive substances. For the carbon steel version, the joint bearings are made of stainless steel.

Sizes are available from 3" to 8" for floating roof tanks with an external floating roof.

**PROTEGO® Floating Roof Drainage Systems are „Made in Germany“ and will provide many years of trouble free tank operation.**

### Selection and Design

PROTEGO® Floating Roof Drainage Systems are the result of extensive experience and are well-conceived solutions for the end-user. This includes easy installation, assembly, and full project documentation with design drawings considering tank installations.

The flexibility of the metal hose is possible due to the shackle-bolted joint. Forces caused by torsion or uneven movements of the floating roof are absorbed through design and arrangement of the joints and have no negative effects on the system or metal hoses. The water is drained by metal hoses that are directly connected to the scissor pipes. The drain water does not pass through the actual joints, so sealing elements used for common swivel joint systems are not required.

For stability reasons, metal hose joints are made of steel or stainless steel.

Options upon request:

- Roof drain valve
- Bottom pipe
- On-site support

\*Project:  
Location:  
Customer:  
\*End user:  
\*Engineering:

**Tank Main Details**

*Floating roof tank	<input type="checkbox"/>	
Tank No.:	*Tank height: :	mm *Tank diameter: mm
*Maximum filling height:	mm	
* Material design of Floating Roof Drainage System:		

**Product Details**

*Product stored:	
*Specific density:	
Maximum product temperature:	°C

**Tank Details**

*Nominal diameter of drain line: DN	
*Height of connection flange / length of connection piece (inside):	mm
*Manhole size: DN	
Bottom slope:	<input type="checkbox"/>
Slope direction:	
*Are there any obstructions? (supports, heating pipes, etc.)	<input type="checkbox"/>
	if <input checked="" type="checkbox"/> - please specify
*Tank drawing / sketch	<input type="checkbox"/>
	if <input checked="" type="checkbox"/> - please specify

\* This information must be provided upon request.  
Fill in and  check, if applicable.



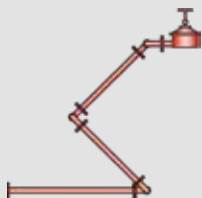

## Floating Roof Drainage System with Swivel Joints



**PROTEGO® SE/CK**

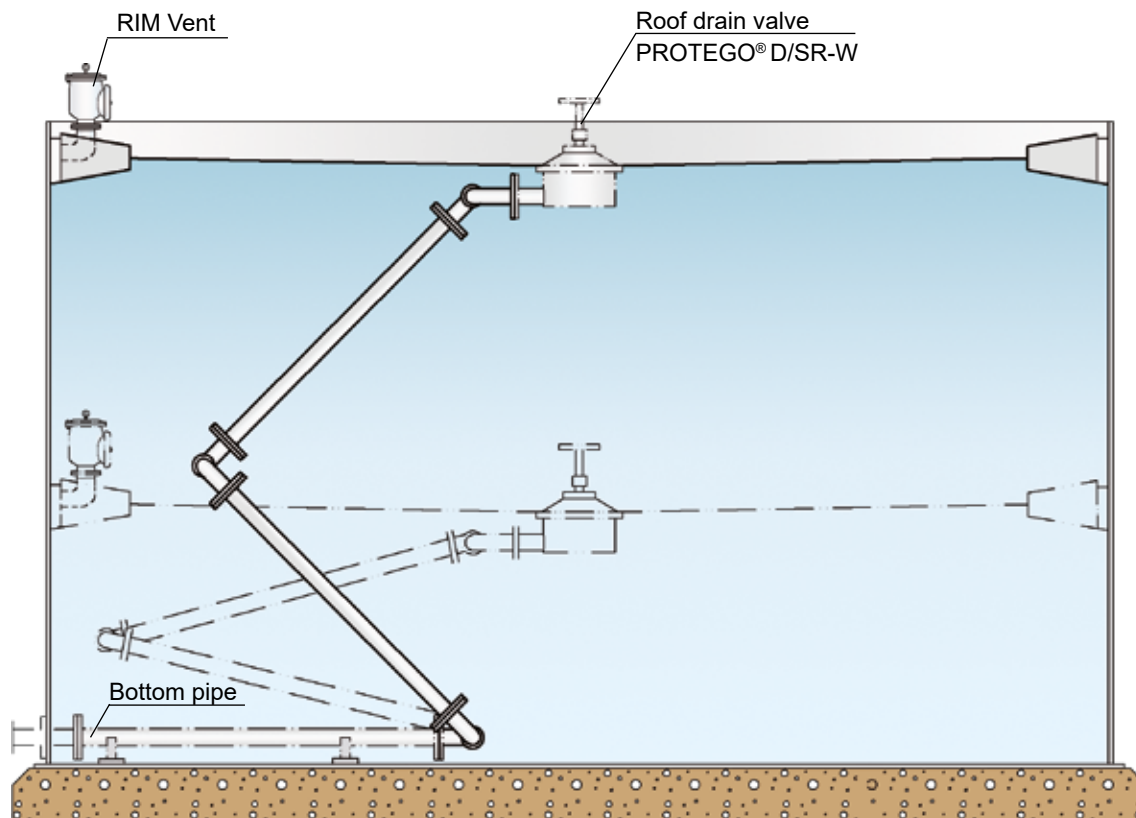

### Function and Description

Floating roof tanks require a drainage system that automatically drains the accumulating rainwater from the floating roof. PROTEGO® SE/CK is a single scissor pipe system that works with swivel joints.

The upper scissor pipe is connected to the roof drain valve, and the lower scissor pipe is connected to the bottom pipe. The water is drained from the tank through the drainage system via the opened roof drain valve.

### Design Types and Specifications

PROTEGO® floating roof drainage systems are designed and sized to suit the individual tank specifications and customer requirements.

PROTEGO® floating roof drainage systems are designed for long-term operation in full contact with the substances used. We use carbon steel or stainless steel for highly loaded components or aggressive substances.

Sizes are available from DN 80/3" to DN 200/8" for floating roof tanks with external floating roof.

### Selection and Design

PROTEGO® Floating Roof Drainage Systems are the result of extensive experience and are well-conceived solutions for the end-user. This includes easy installation, assembly, and full project documentation with drawings considering tank installations.

Essential for the design of the PROTEGO® Floating Roof Drainage System is the Heavy Duty Swivel Joint, which is designed to work maintenance-free for many years in full contact with the substances used. This design provides the tank operator with operational reliability, and unforeseen and expensive repairs are prevented.

The Swivel Joints are:

- made of carbon steel or stainless steel;
- lubricated with a maintenance-free lifetime lubrication system; and
- equipped with a double row ball bearing with larger sizes to optimize reliability.

Options upon request:

- Roof drain valve
- Bottom pipes
- On-site support

**PROTEGO® Floating Roof Drainage Systems are „Made in Germany“ and will provide many years of trouble free tank operation.**

\*Project:  
Location:  
Customer:  
\*End user:  
\*Engineering:

**Tank Main Details**

*Floating roof tank	<input type="checkbox"/>	
Tank No.:	*Tank height: :	mm *Tank diameter: mm
*Maximum filling height:	mm	
* Material design of Floating Roof Drainage System:		

**Product Details**

*Product stored:	
*Specific density:	
Maximum product temperature:	°C

**Tank Details**

*Nominal diameter of drain line: DN	
*Height of connection flange / length of connection piece (inside):	mm
*Manhole size: DN	
Bottom slope:	<input type="checkbox"/> Slope direction:
*Are there any obstructions? (supports, heating pipes, etc.)	<input type="checkbox"/>
	if <input checked="" type="checkbox"/> - please specify
*Tank drawing / sketch	<input type="checkbox"/>
	if <input checked="" type="checkbox"/> - please specify

\* This information must be provided upon request.  
Fill in and  check, if applicable.



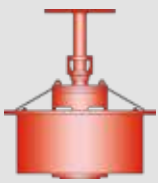

# Roof Drain Valves



## PROTEGO® D/SR and D/SR-W

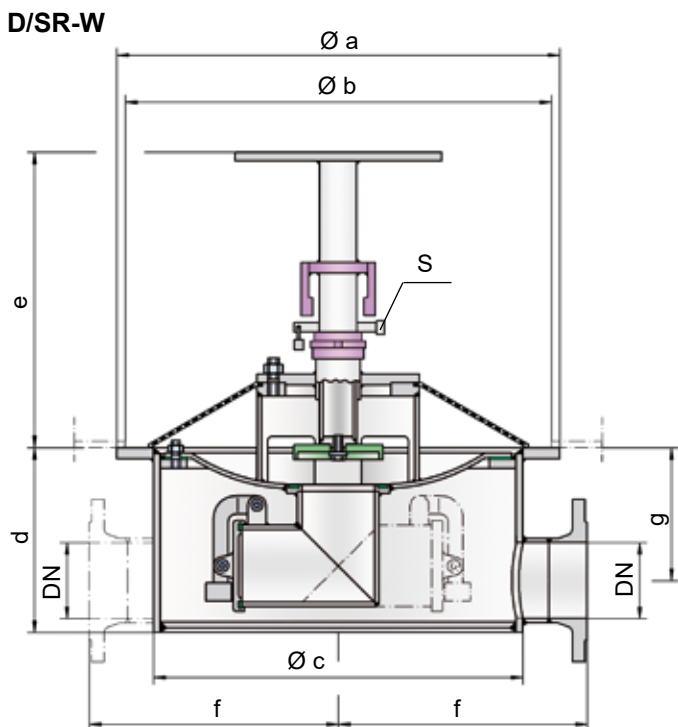
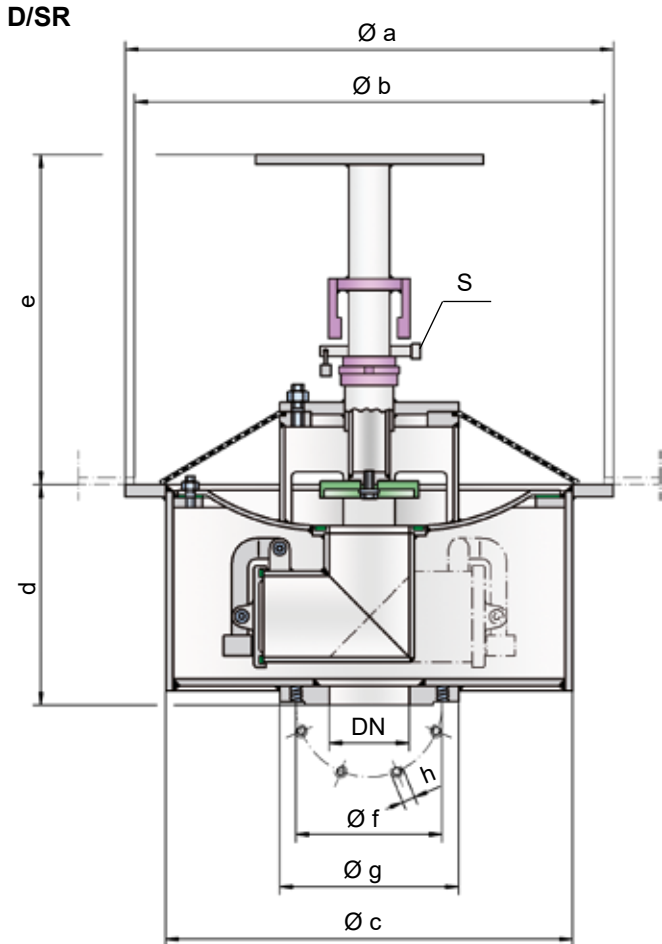

### Function and Description

The PROTEGO® roof drain valves D/SR or D/SR-W have the function of an inlet cup, which collects the rainwater from the floating roof through the scissor pipes of a PROTEGO® floating roof drainage system, e.g., SE/K or SE/CK, into the sewage system.

Under normal operating conditions, the roof drain valve is open. In case of any leakage, the non-return valve prevents the stored substance from escaping to the floating roof. The inlet screen protects the roof drain valve from any dirt, leaves, or nesting animals.

### Design Types and Specifications

Two designs are available:

Roof drain valve with vertical connection **D/SR**

Roof drain valve with horizontal connection **D/SR-W**

As an option, a special design of the roof drain valve is available with protection against unauthorized closing of the quick-action shut-off (S).

**Table 1: Dimensions D/SR** Dimensions in mm / inches

DN	80 / 2"	100 / 4"	150 / 6"
a	550 / 21.65	600 / 23.62	650 / 25.59
b	490 / 19.29	540 / 21.26	590 / 23.23
c	450 / 17.72	500 / 19.69	550 / 21.65
d	240 / 9.45	280 / 11.02	330 / 12.99
e	490 / 19.29	490 / 19.29	490 / 19.29
f	160 / 6.3	180 / 7.09	240 / 9.45
g	200 / 7.87	220 / 8.66	285 / 11.22
h	M 16	M 16	M 20

**Table 2: Dimensions D/SR-W** Dimensions in mm / inches

DN	80 / 2"	100 / 4"	150 / 6"
a	550 / 21.65	600 / 23.62	650 / 25.59
b	490 / 19.29	540 / 21.26	590 / 23.23
c	450 / 17.72	500 / 19.69	550 / 21.65
d	205 / 8.07	250 / 9.84	320 / 12.6
e	490 / 19.29	490 / 19.29	490 / 19.29
f	285 / 11.22	320 / 12.6	350 / 13.78
g	150 / 5.91	180 / 7.09	225 / 8.86

**Table 3: Material selection**

Design	A	B
Housing	Steel	Stainless Steel
Non-return valve	Red Brass	Red Brass
Valve disc	Steel	Stainless Steel
Quick-action shut-off	Steel	Stainless Steel
Gasket	PUR	PUR

The device must have sufficient corrosion resistance to the stored substance. If necessary, designs in special stainless steel quality should be selected.

### Flange Connection Type

In type PROTEGO® D/SR, the housing bottom is equipped with a loose flange on the underside with threaded holes in accordance with EN 1092-1 or, optionally, to any other international standard.

In the standard model of PROTEGO® D/SR-W, the housing is equipped with a lateral flange connection in accordance with EN 1092-1 or, optionally, to any other international standard. An additional flange connection is available

### Selection and Design

The specified maximum rainfall is required to determine the required nominal size. Alternatively, the connection size of the roof drain valve corresponds with the existing nominal dimension of the floating roof drainage system. Roof drain valves with 2 or 3 non-return valves are available as an option.

### Necessary Data for Specification

Maximum rainfall to be drained off (m<sup>3</sup>/h or CFH)

Material of floating roof

Connection size of the floating roof drainage system DN (mm or inches)

Design of floating roof drainage system

### Application Examples

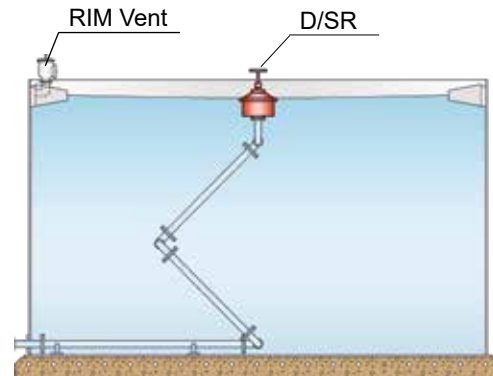

PROTEGO® roof drain valve type D/SR in combination with Floating roof drainage system PROTEGO® SE/CK

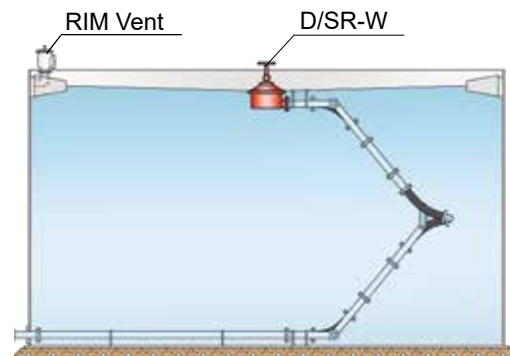

PROTEGO® roof drain valve type D/SR-W in combination with Floating roof drainage system PROTEGO® SE/K.



for safety and environment

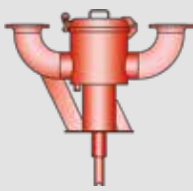

## Vent Valve, Lift-actuated



### PROTEGO® AL/DK and PROTEGO® AL 200

#### AL/DK

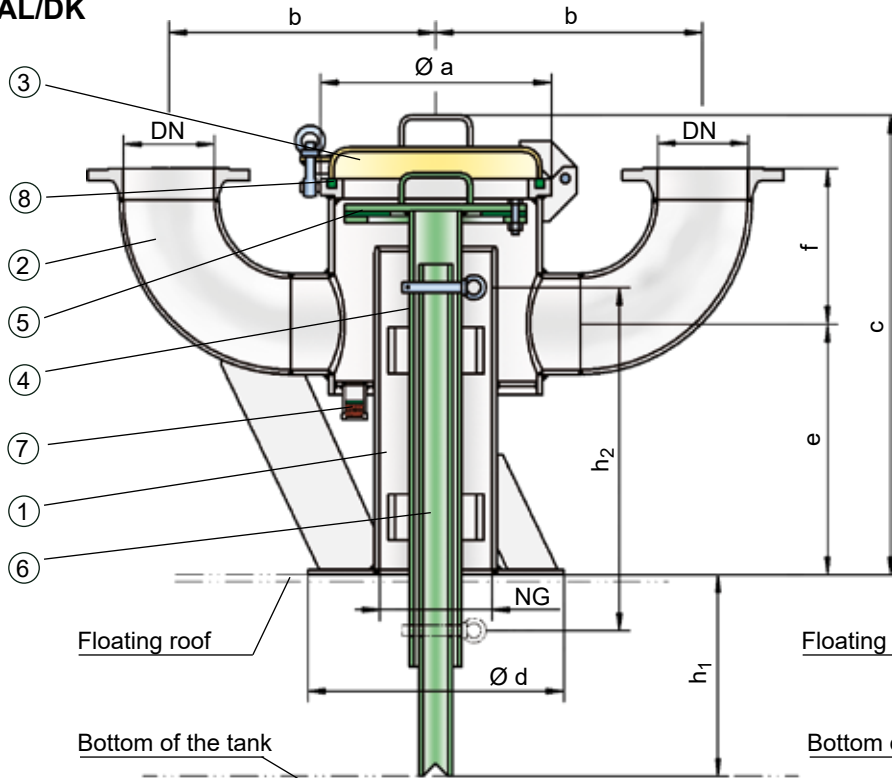

#### AL 200

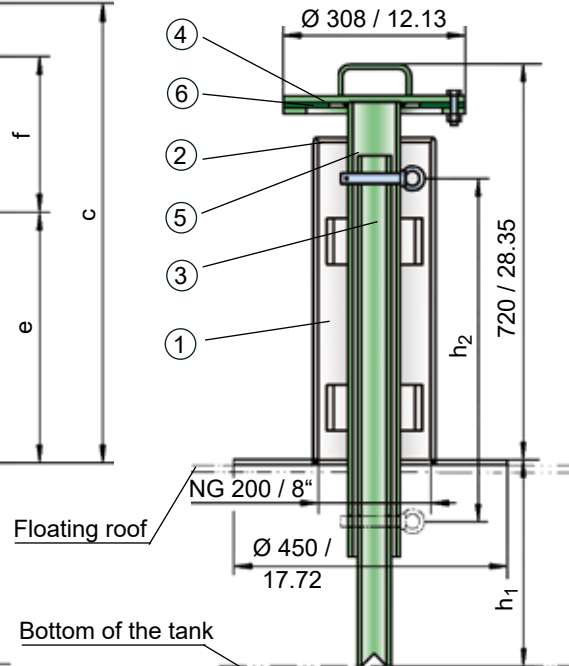

Dimensions in mm / inches

### Function and Description

PROTEGO® lift-actuated vent valves type AL/DK provide automatic venting of floating roof tanks when the floating roof is lowered onto its supports and the tank is either drained or refilled. When the floating roof is in its lowest position, the valve is forced to open through lift actuation, which prevents inadmissible vacuum during final draining or inadmissible pressure during refilling.

The PROTEGO® AL/DK valve consists of a housing (1) with a sheet metal panel to be welded onto the floating roof, two or four connection nozzles (2) for installation of vent caps, cover (3), lift (4) including valve disc (5), lift pipe (6), and the condensate drain valve (7) which can be designed to be flame transmission proof. The condensate drain is sealed by a flat gasket attached to the valve disk (5). The cover (3) is sealed by a sealing cord (8).

In general the device PROTEGO® AL 200 consists of a housing (1) with sheet-metal panel to be welded on the floating roof as well as the valve seat (2), lift (3) including valve pallet (4) and lift pipe (5). A flat gasket (6) provides sealing.

As the lowest position of the floating roof varies for operation and assembly, specify the dimensions  $h_1$  and  $h_2$ :

$h_1$ : Distance between the lower edge of sheet-metal panel (or mounting flange) and the tank bottom in lowest position of floating roof (operating position with an empty tank).

$h_2$ : Distance between the floating roof in lifted maintenance position and the height of the floating roof in fully lowered operating position (operating position with an empty tank).

If the floating roof supports are changed from operating position to maintenance position, the lift has to be extended as well. This is done with an adjustable locking pin that is secured with a split pin.

The valve is not flame transmission proof.

Based on a hazard analysis with regard to material selection and function, the valves have no potential ignition sources. As a result, they are not subject to the European Explosion Protection Directive (ATEX) when used in explosive atmospheres.



## Designs and Specifications

**Table 1: Dimensions for AL/DK**

NG	200 / 8"	200 / 8"	200 / 8"	200 / 8"
DN	80 / 3"	100 / 4"	150 / 6"	200 / 8"
a	350 / 13.78	350 / 13.78	350 / 13.78	350 / 13.78
b	465 / 18.31	465 / 18.31	465 / 18.31	515 / 20.28
c	870 / 34.25	870 / 34.25	870 / 34.25	870 / 34.25
d	450 / 17.72	450 / 17.72	450 / 17.72	450 / 17.72
e	345 / 13.58	360 / 14.17	385 / 15.16	415 / 16.34
f	460 / 18.11	445 / 17.52	285 / 11.22	370 / 14.57

Dimensions in mm / inches

**Table 2: Material**

Housing	Steel	Special materials upon request.
Valve guide	Stainless Steel	
Gasket	FPM	

**Table 3: Flange connection type DN**

EN 1092-1, Form B1	Other types upon request.
ASME B16.5 CL 150 R.F.	

## Selection and Design

The required amount and nominal size DN is determined based on the calculated flow rate from the thermal venting and pump rate in lowest floating roof position ( $\text{Nm}^3/\text{h}$  or CFH) and on the maximum acceptable tank pressure  $p_T$  (mbar / inch W.C.) according to the flow capacity charts. Special designs are available upon request.

Flow rates and pressure losses of vent caps PROTEGO® EB or PROTEGO® LH/AD have to also be considered according to the appropriate charts in the relevant data sheets. If pure venting is required, lift-actuated vent valves PROTEGO® AL 200 can be used.

## Necessary Data for Specification

Stored product

Tank diameter (m or ft)

Tank height (m or ft)

Support height  $h_1$  (operating position with empty tank)

Support height  $h_2$  (lifted assembly position)

Maximum allowable tank pressure  $p_T$  (mbar or inch W.C.)

Pump rate ( $\text{m}^3/\text{h}$  or CFH)

## Application Examples for PROTEGO® AL/DK

Lift-actuated vent valves PROTEGO® AL/DK can be combined with vent caps PROTEGO® EB which are deflagration-proof and endurance burning-proof. This ensures flame transmission-proof ventilation.

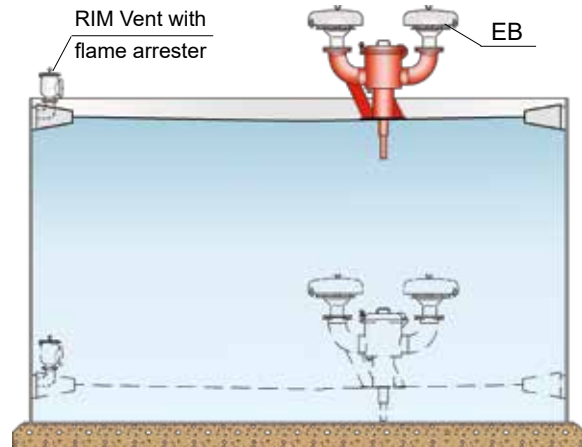

If endurance burning-proof is not required, the valves can be combined with deflagration-proof PROTEGO® LH/AD devices. The applicable data sheets are available in Sec. 2 "Deflagration Flame Arresters, End-of-Line and Vent Caps".

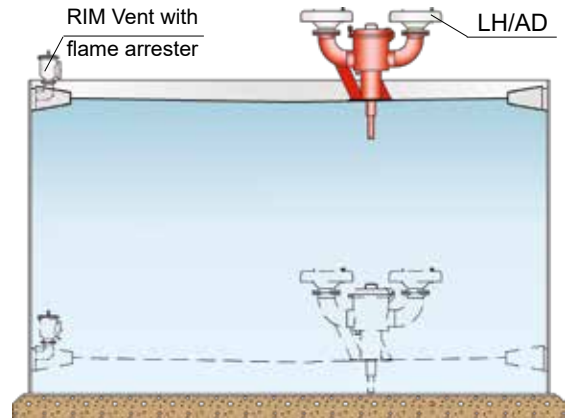

## Application Examples for PROTEGO® AL 200

PROTEGO® AL 200 for fixed roof storage tanks with internal floating roof.

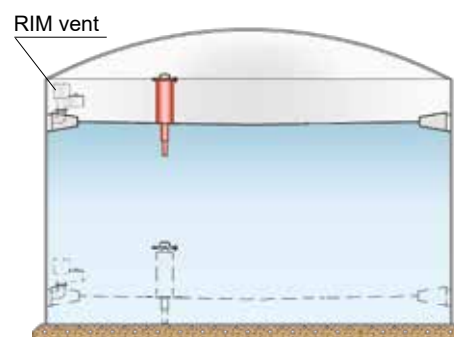

**PROTEGO**  
for safety and environment

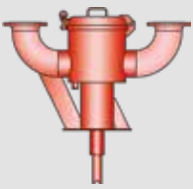

# Vent Valve, Lift-actuated

## Flow Capacity Charts

### PROTEGO® AL/DK and PROTEGO® AL 200

DN 200 - 100 / 8" - 4"  
 DN 200 - 150 / 8" - 6"  
 DN 200 - 200 / 8" - 8"

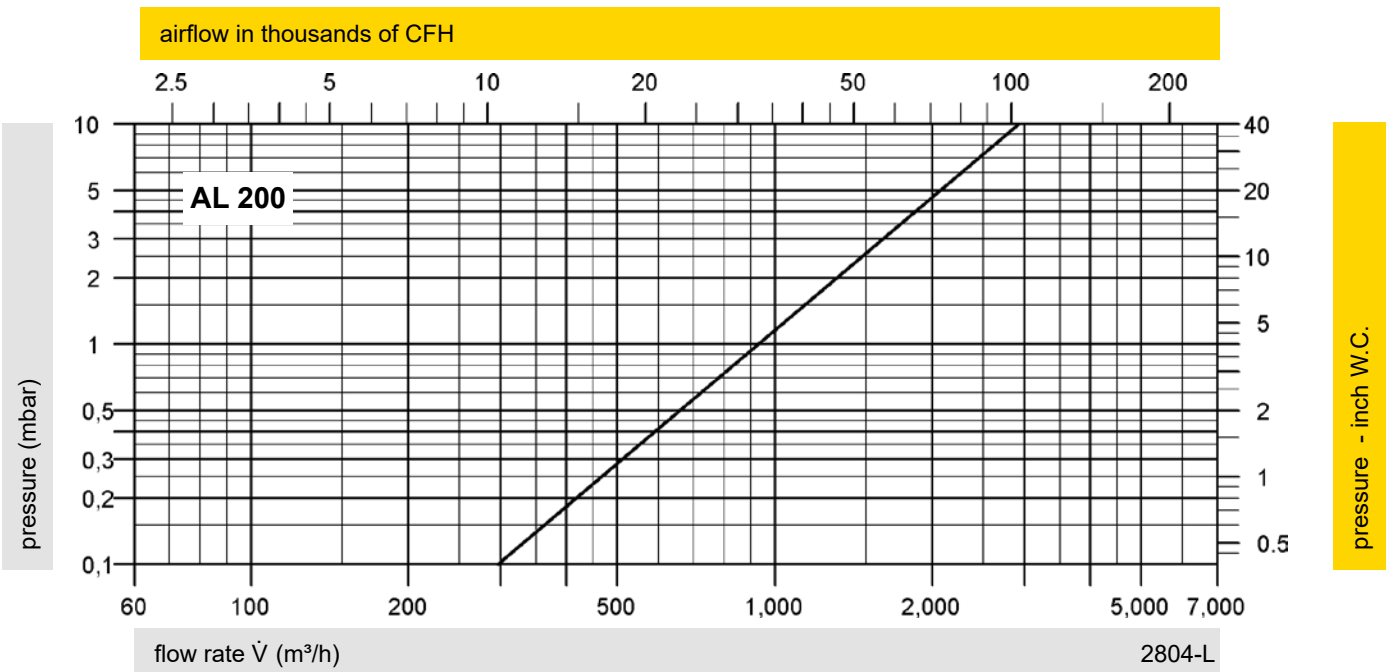
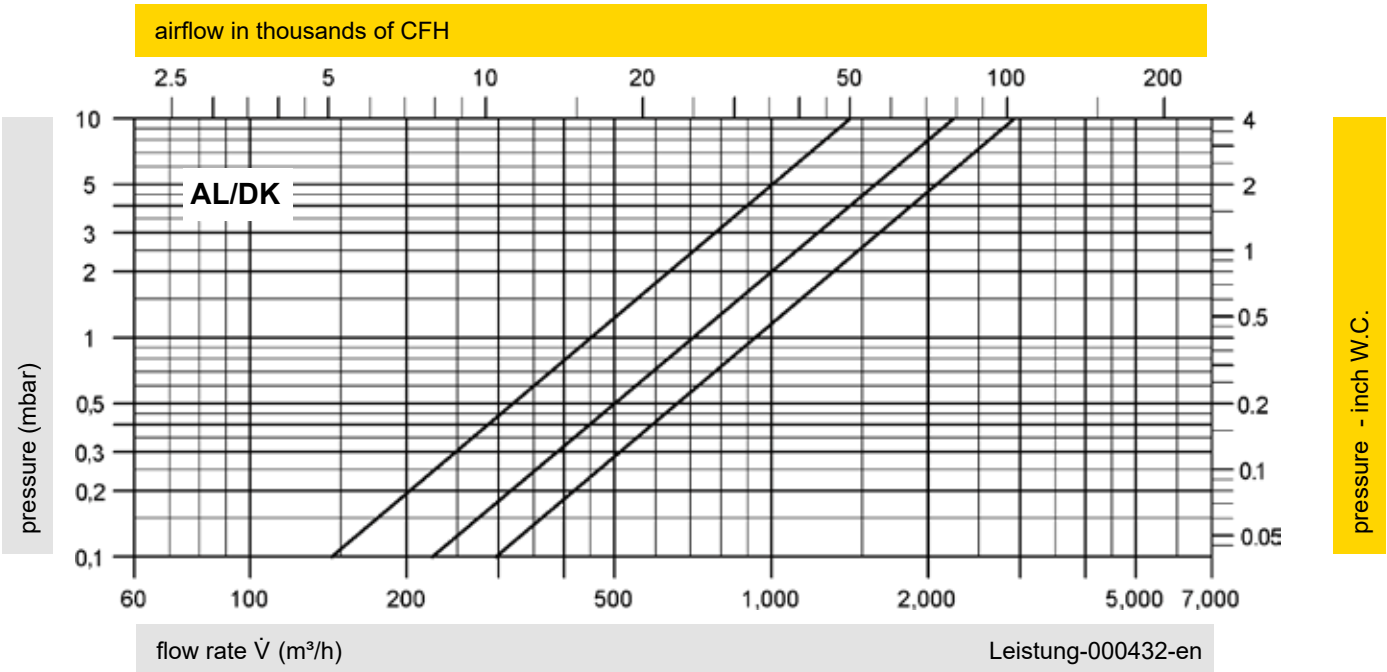

The flow capacity charts have been determined with a calibrated and TÜV certified flow capacity test rig. Volume flow  $\dot{V}$  in (m³/h) and CFH refer to the standard reference conditions of air in ISO 6358 (20°C, 1bar). For conversion to other densities and temperatures, refer to Sec. 1: "Technical Fundamentals."





# Gauge Hatch with Flange



## PROTEGO® PF/K, PF/TK and PS/KF

### PROTEGO® PF/K

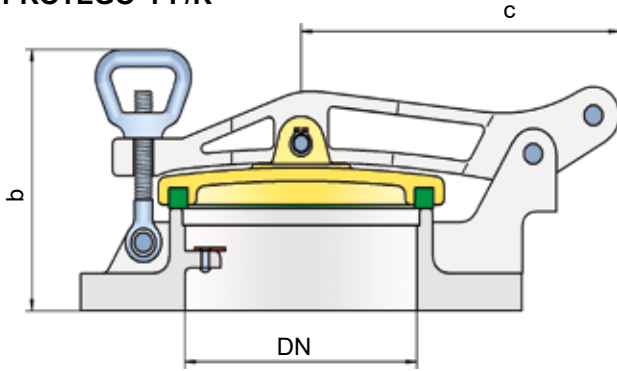

Design "I"  
remaining open

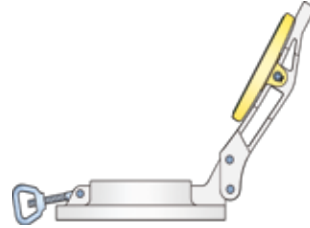

Design "II"  
automatic cover closing

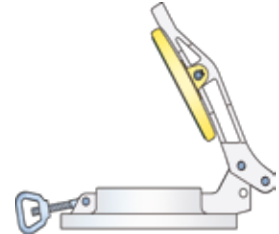

### PROTEGO® PF/TK

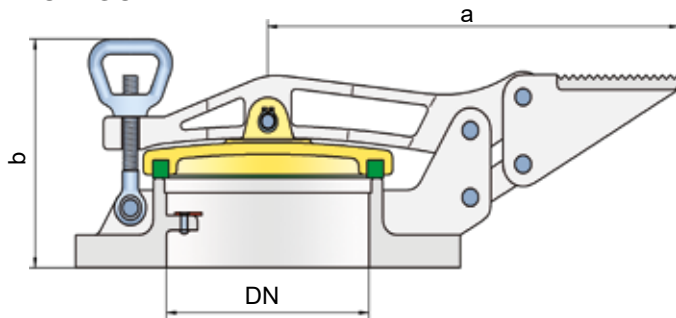

Pedal-operated version  
automatic cover closing

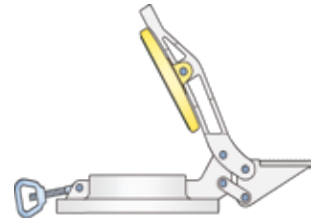

### PROTEGO® PS/KF

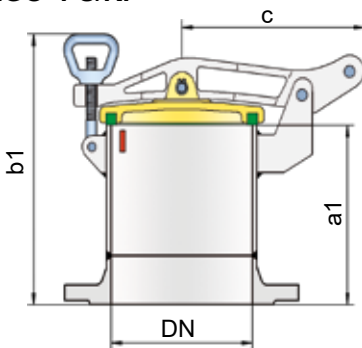

Design "I"  
remaining open

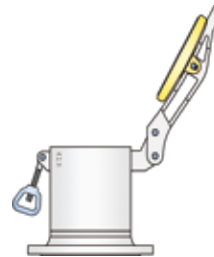

Design "II"  
automatic cover closing

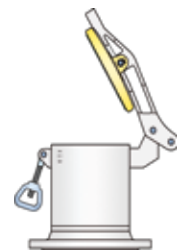

### Function and Description

PROTEGO® gauge hatches types PF/K, PF/TK, and PS/KF are used as lockable gauge nozzles which are only opened for gauging or sampling. Otherwise, they are tightly closed.

The gauge hatches PROTEGO® PF/K, PF/TK, and PS/KF mainly consist of housing, cover, and bracket. The housing is equipped with stainless steel gauge marks as standard.

In the pedal-operated version PROTEGO® PF/TK, the gauging nozzle pedal is connected to both the housing and the bracket.

## Design Types and Specifications

Depending on the intended use, the following designs are available:

- Gauge hatch with flange **PF/K** design I and II  
 „I“ : remaining open  
 „II“ : automatic cover closing
- Gauge hatch with flange and pedal **PF/TK** automatic cover closing
- Gauge hatch with flange nozzle **PS/KF** design I and II  
 „I“ : remaining open  
 „II“ : automatic cover closing

PROTEGO® PS/K and PS/TK are available for welding onto the tank. A separate data sheet is available.

Table 1: Dimensions		Dimensions in mm / inches		
DN	100 / 4"	150 / 6"	200 / 8"	
a	260 / 10.24	305 / 12.01	335 / 13.19	
b	150 / 5.91	155 / 6.10	175 / 6.89	
c	160 / 6.30	205 / 8.07	235 / 9.25	
a1	225 / 8.86	265 / 10.43	300 / 11.81	
b1	315 / 12.40	360 / 14.17	405 / 15.94	

The nominal size depends on the dimensions of the gauging and sampling device.

Table 2: Material selection				
Design	A	B	C	D
Housing	Ductile Iron*	Stainless Steel	Aluminum	Steel
Cover	Ductile Iron*	Stainless Steel	Aluminum Stainless Steel**	Steel

The combination of steel and aluminum in explosive environments is prohibited due to risk of ignition.

\* only for PF/K and PF/TK

\*\* only for PF/TK-100

## Flange Connection Type

The flange connection is in accordance with EN 1092-1, Form A. Optionally, the connecting flange can be made in accordance with any international standard.

## Necessary Data for Specification

Stored product

Tank material

Tank nozzle DN (mm or inches)

## Application Examples

Gauge hatches can, for example, be used in combination with the manual gauge devices PROTEGO® H/P or with the gauging and sampling device PROTEGO® VP/HK.

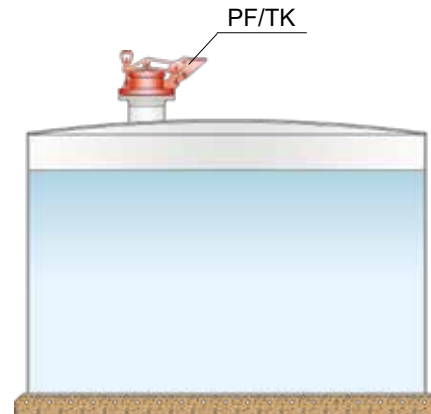

Gauge hatches can be installed on tanks with floating roofs.

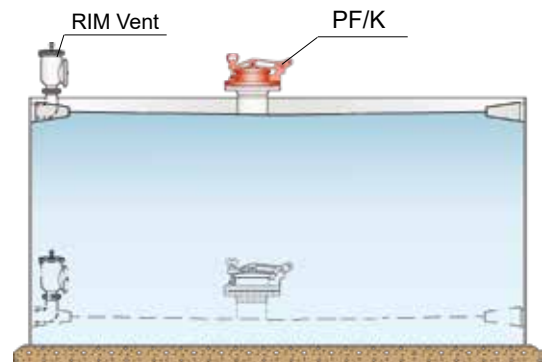

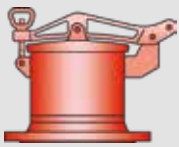

## Gauge Hatch with Welded nozzle

PROTEGO® PS/K, PS/TK



### PROTEGO® PS/K

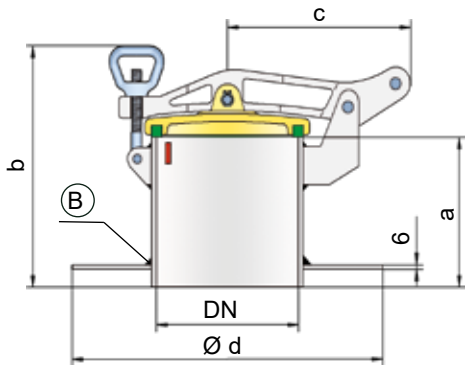

Design "I"  
remaining open

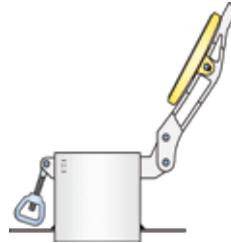

Design "II"  
automatic cover closing

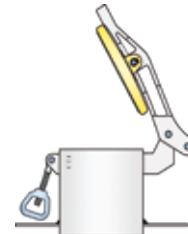

### PROTEGO® PS/TK

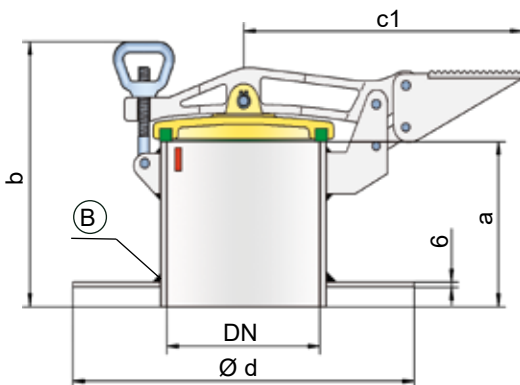

Pedal-operated version  
automatic cover closing

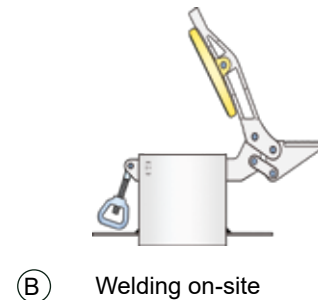

### Function and Description

PROTEGO® gauge hatches PS/K and PS/TK are used as lockable gauge nozzles which are only opened for gauging or sampling.

The gauge hatches PROTEGO® PS/K and PS/TK mainly consist of housing, cover, and bracket. As a standard, the housing has stainless steel gauge marks.

In the pedal-operated version PROTEGO® PS/TK, the gauging nozzle pedal is connected to both the housing and the bracket

### Design Types and Specifications

Depending on the intended use, the following designs are available:

Gauge hatch with welding nozzle

**PS/K** design I and II  
„I“ : remaining open  
„II“ : automatic cover closing

Gauge hatch with welding nozzle and pedal

**PS/TK** automatic cover closing

Gauge hatches with flange are available as type PROTEGO® PF/K, PF/TK and PS/KF. A separate data sheet is available.

Table 1: Dimensions		Dimensions in mm / inches	
DN	100 / 4"	150 / 6"	200 / 8"
a	175 / 6.89	225 / 8.86	250 / 9.84
b	265 / 10.43	320 / 12.60	355 / 13.98
c	160 / 6.30	205 / 8.07	235 / 9.25
c1	260 / 10.24	305 / 12.01	335 / 13.19
d	275 / 10.83	350 / 13.78	450 / 17.72

The nominal size depends on the dimensions of the gauging and sampling device.

Table 2: Material selection		
Design	A	B
Housing	Steel	Stainless Steel*
Cover	Ductile Iron	Stainless Steel*

\* Only for PS/K

### Flange Connection Type

The flange connection is in accordance to EN 1092-1, Form A. Optionally, the connecting flange can be made in accordance with any international standard.

### Necessary Data for Specification

Stored product

Tank material

Tank nozzle DN (mm or inches)

### Application Examples

Gauge hatches can, for example, be used in combination with the manual gauge devices type PROTEGO® H/P or with the gauging and sampling device PROTEGO® VP/HK.

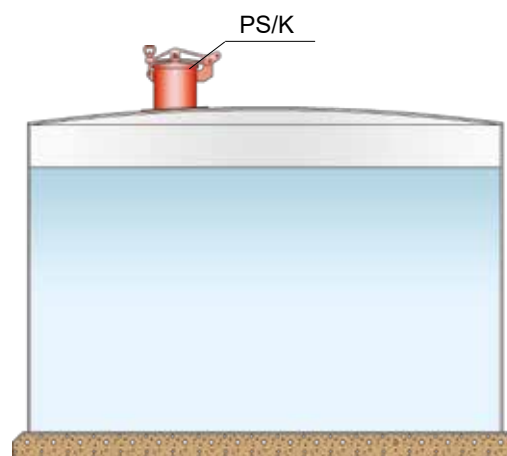

Gauge hatches can be welded onto tanks with floating roof.

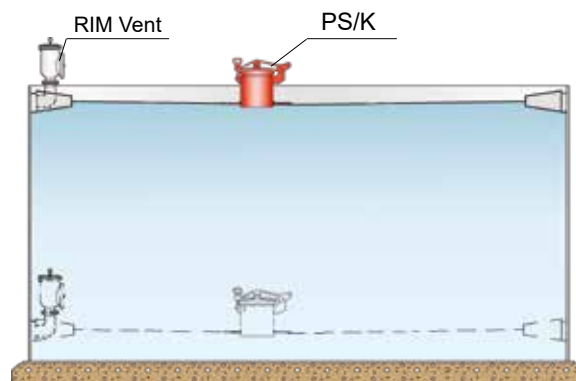



# Sampling and Air Bleed Valve

Deflagration-proof

**PROTEGO® ZE/WU**

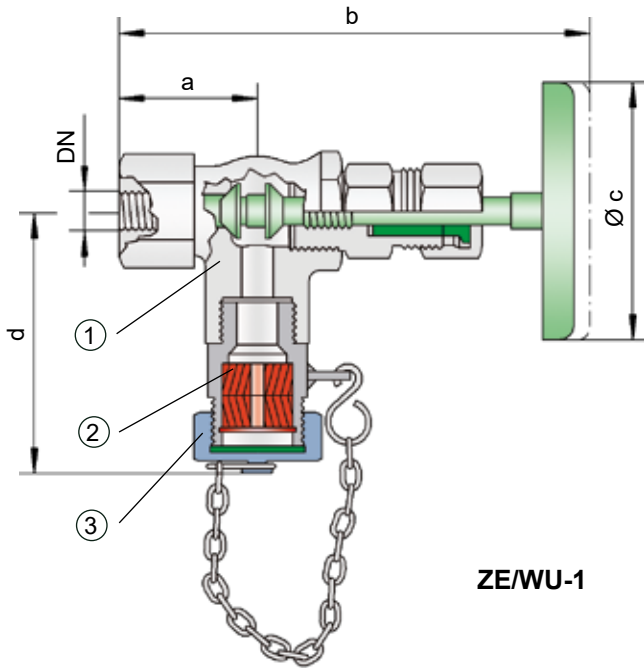

**ZE/WU-1**

Standard design up to PN 25

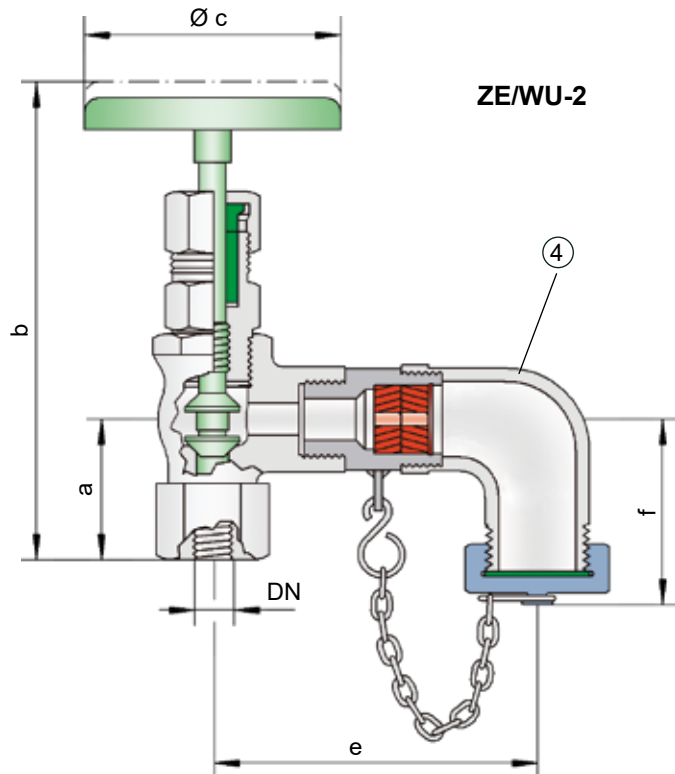

**ZE/WU-2**

## Function and Description

The PROTEGO® sampling and air bleed valve is used for flame transmission-proof venting of pipelines and equipment that transports or processes flammable liquids and for taking liquid samples. The valve incorporates an end-of-line deflagration flame arrester. Should the gas/air mixtures or product vapor/air mixtures ignite during venting, the valve prevents flash back into the protected system.

The sampling and air bleed valve PROTEGO® ZE/WU consists of the threaded angle valve in pressure stage PN25 (1) with hand wheel as standard design, a female threaded connection (pipe thread G½" up to G1"), and the flame arrester (2) with cover (3).

Optionally, an elbow fitting (4) is available as outlet for sampling. The PROTEGO® flame arrester (2) consists of the flame arrester casing with FLAMEFILTER®.

The valve opens manually with the hand wheel. For sampling, a suitable container is required.

The simple and sturdy design makes it suitable for nearly all flammable liquids. This device can be installed in any position.

Flame transmission protection is guaranteed against atmospheric deflagrations of gas/air mixtures or product vapor/air mixtures of explosion groups up to IIB IIB (NEC group D to C) up to an operating temperature of +60°C / 140°F and an absolute operating pressure of up to 1.1 bar / 15.9 psi.

Type-approved in accordance with the current ATEX Directive and EN ISO 16852, as well as other international standards.

## Designs and Specifications

There are two designs available:

Sampling and air bleed valve, standard design **ZE/WU - 1**

Sampling and air bleed valve with elbow **ZE/WU - 2**

Special designs for higher pressures are available

Also available with flange connection (see figure).

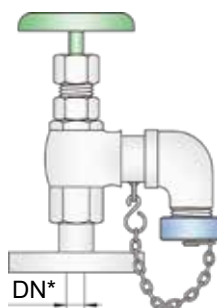

\* The flange is available in drilling pattern and thickness for DN15 / ½", DN20 / ¾", DN25 / 1", DN32 / 1¼", DN40 / 1½", and for PN25/40 or PN100 upon request.



<b>Table 1: Dimensions</b>		Dimensions in mm / inches				
DN	a	b	Ø c	d	e	f
15 / G½"	40 / 1.57	140 / 5.51	70 / 2.76	80 / 3.15	96 / 3.78	67 / 2.64
20 / G¾"	50 / 1.97	165 / 6.50	85 / 3.35	80 / 3.15	89 / 3.50	67 / 2.64
25 / G1"	65 / 2.56	200 / 7.87	100 / 3.94	95 / 3.74	104 / 4.09	67 / 2.64

<b>Table 2: Explosion group</b>		
MESG	Expl. Gr. (IEC/CEN)	Gas Group (NEC)
≥ 0,50 mm	IIB	B

<b>Table 3: Material</b>	
Design	A
Threaded angle valve	Stainless Steel
Elbow	Stainless Steel
Cover	Stainless Steel
FLAMEFILTER®	Stainless Steel

The valve must be sufficiently resistant to corrosion through the gas/air mixtures or product vapor/air mixtures. This applies especially to the FLAMEFILTER®.

<b>Table 4: Type of connection</b>	
Pipe thread DIN ISO 228 T1	DIN





# Condensate Drain Valve

Deflagration-proof

PROTEGO® ZE/TK



## ZE/TK-1

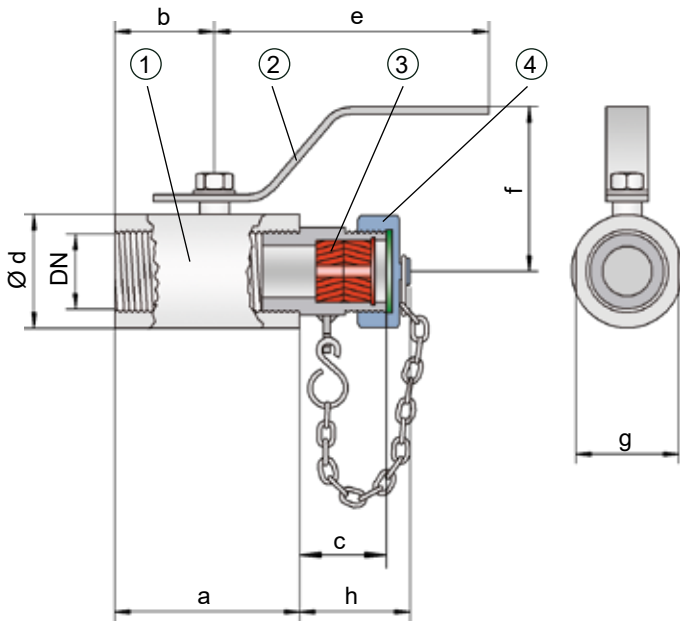

## Function and Description

The PROTEGO® ZE/TK condensate drain valve is used for flame transmission-proof condensate drainage of devices or plant equipment (e.g., tanks, pipelines, etc.) where flammable liquids can form condensate and flammable product vapor/ air mixtures could develop. They can also be used for the venting of tanks, plant components, and pipes that transport or process flammable liquids. The drain valve incorporates an end-of-line deflagration flame arrester.

The condensate drain valve PROTEGO® ZE/TK consists of the ball valve (1) with hand lever (2), a female threaded connection (e.g., pipe thread G½" up to G1"), and the flame arrester (3) with cover (4).

The elbow fitting (5) is also available as an optional outlet.

The flame arrester (3) consists of the flame arrester casing and FLAMEFILTER®.

The ball valve is opened with the hand lever. When draining condensate, a suitable container is required. When draining flammable and/or toxic products, observe the appropriate safety provisions.

The simple and sturdy design is suitable for nearly all flammable liquids and can be installed in any position.

Flame transmission protection is guaranteed against atmospheric deflagrations of product vapor/air mixtures of explosion groups up to IIB (NEC groups D to C) up to an operating temperature of +60°C/140°F and an operating pressure up to 1.1 bar/15.9 psi.

Type-approved in accordance with the current ATEX Directive and EN ISO 16852, as well as other international standards.

## ZE/TK-2

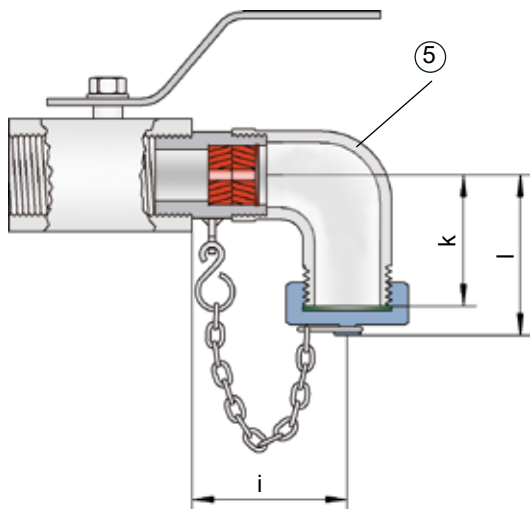

## Designs and Specifications

There are two designs available:

Condensate drain valve, standard design **ZE/TK - 1**

Condensate drain valve with elbow **ZE/TK - 2**

Special designs are available upon request.

**Table 1: Dimensions**

Dimensions in mm / inches

DN	a	b	c	Ød	e	f	g	h	i	k	l
15 / G½"	60 / 2.36	30 / 1.18	33 / 1.30	32 / 1.26	110 / 4.33	55 / 2.17	27 / 1.06	45 / 1.77	54 / 2.13	38 / 1.50	67 / 2.64
20 / G¾"	65 / 2.56	35 / 1.38	33 / 1.30	38 / 1.50	110 / 4.33	60 / 2.36	34 / 1.34	45 / 1.77	54 / 2.13	38 / 1.50	67 / 2.64
25 / G1"	73 / 2.87	40 / 1.57	33 / 1.30	45 / 1.77	110 / 4.33	65 / 2.56	41 / 1.61	45 / 1.77	54 / 2.13	38 / 1.50	67 / 2.64

**Table 2: Explosion group**

MESG	Expl. Gr. (IEC/CEN)	Gas Group (NEC)
≥ 0,50 mm	IIB	B

**Table 3: Material**

Ball valve	Stainless Steel
Elbow	Stainless Steel
Cover	Stainless Steel
FLAMEFILTER®	Stainless Steel

The valves must be sufficiently resistant to corrosion through the gas/air mixtures or product vapor/air mixtures. This applies especially to the FLAMEFILTER®. If necessary, designs in special stainless steel quality should be selected.

**Table 4: Type of connection**

Pipe thread DIN ISO 228 T1	DIN
----------------------------	-----



for safety and environment

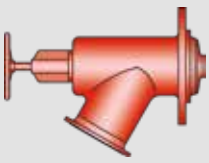

**In-tank Valve**  
**Internal Safety Valve**

**PROTEGO® SI/F**

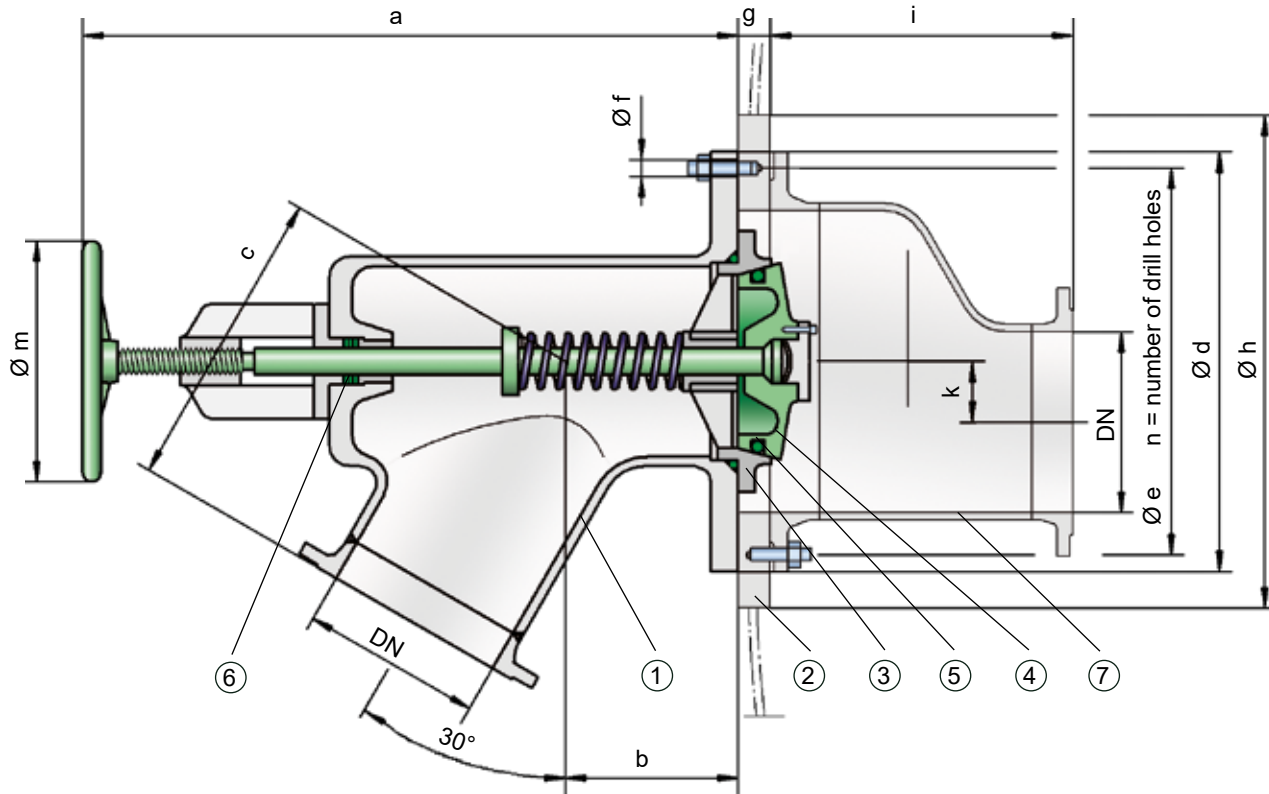

**Function and Description**

The PROTEGO® SI/F in-tank valve is a shut-off valve and protects the downstream liquid lines of storage tanks and containers in process plants in the chemical, petrochemical, and pharmaceutical industries. This valve also increases safety and operation of the equipment. These valves are also known as in-tank valves.

The in-tank valve SI/F (figure 1) consists of the housing (1), mounting flange (2), valve seat (3), valve disc (4), and sealing (5). The mounting flange is welded into the tank shell. The valve seat is replaceable. The valve seat and valve disc are lapped metallic surfaces and an additional O-ring is installed to ensure the required tightness. The spindle sealing (6) can be adjusted or replaced and is designed for a test pressure of 25 bar / 363 psi.

The external connection piece of the housing is fitted with an operating valve, which is supplied by the customer, and is used for normal operation. The internal safety valve is kept open during normal operation. It is only closed in the event of a longer operation interruption, in an emergency, or for necessary repairs.

It is closed by an “internal sealing”, i.e., the valve is closed inside of the tank. This prevents the tank from leaking even if external components or leaks in any connected pipelines are destroyed.

Due to the special design of PROTEGO® in-tank valves SI/F, in which only the mounting flange (2) is welded to the tank shell, almost all other parts can be replaced. Replacement of important external parts does not require draining the tank. This results in significant operational advantages.

The PROTEGO® SI/F is available in various nominal sizes and materials. As an option, the in-tank valve can be equipped with an internal nozzle (7) for mounting a suction and filling pipe or a swing pipe system (SI/FA).

Tank shut-off valves of this type are usually operated manually. Versions with an explosion-proof electric actuator for direct or remote control are also available.

For special tank designs (e.g., full containment tank system), special versions with pneumatic control (PROTEGO® SI/DP) can also be supplied.

**Design Types and Specifications**

Two designs are available:

- |   |              |
|---|--------------|
| In-tank valve, standard design                    | <b>SI/F</b>  |
| In-tank valve with internal connection nozzle (7) | <b>SI/FA</b> |

**Table 1: Dimensions**

Dimensions in mm / inches

DN	a	b	c	d	e	f	g	h	i	k	m	n
50 / 2"	371/14.61	75/2.95	170/6.69	240/9.45	205/8.07	14/0.55	30/1.18	305/12.01	250/9.84	54/2.13	200/7.87	8
65 / 2 ½"	400/15.75	85/3.35	190/7.48	305/12.01	205/8.07	14/0.55	30/1.18	305/12.01	240/9.45	45/1.77	200/7.87	8
80 / 3"	416/16.38	90/3.54	200/7.87	330/12.99	230/9.06	14/0.55	30/1.18	330/12.99	290/11.42	53/2.09	200/7.87	8
100 / 4"	434/17.09	100/3.94	225/8.86	270/10.63	230/9.06	14/0.55	30/1.18	330/12.99	270/10.63	40/1.57	200/7.87	8
150 / 6"	658/25.91	130/5.12	320/2.60	410/16.14	370/14.57	18/0.71	40/1.57	505/19.88	440/17.32	78/3.07	400/15.75	12
200 / 8"	725/28.54	145/5.71	365/14.37	540/21.26	405/15.94	18/0.71	45/1.77	540/21.26	450/17.72	68/2.68	400/15.75	12

**Table 2: Material selection**

Design	A	B
Housing	Steel	Stainless Steel
Valve seat	Stainless Steel	Stainless Steel
Valve disc	Stainless Steel	Stainless Steel
Spring	Stainless Steel	Stainless Steel
Bushing	PTFE	PTFE
Hand wheel	Aluminum	Aluminum
Spindle sealing	PTFE	PTFE
Mounting flange	Steel	Stainless Steel

**Table 3: Flange connection type DN**

EN 1092-1, Form B1	Other types upon request.
ASME B16.5 CL 150 R.F.	

### Selection and Design

Together with our engineers, the valve is designed for each specific application. The relevant plant specifications are considered when defining the required nominal sizes and connection types. Regarding temperature, special operating conditions may require special materials. The mounting flange material must be compatible with the tank material. If there are special requirements for the valve or operating parameters, please contact us. Special designs may also be necessary.

### Necessary Data for Specification

Stored medium

Tank height (m or ft)

Tank material

Connection diameter of drain pipe, DN (mm or inch)

### Application Examples

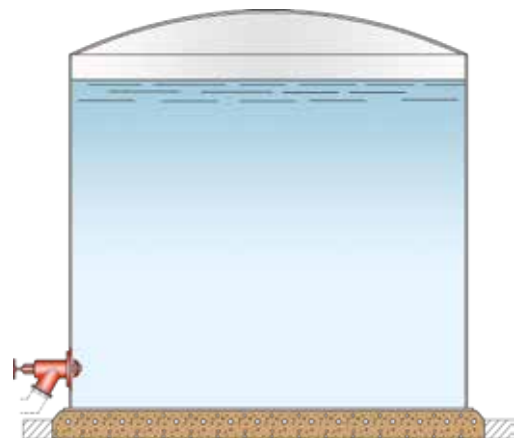

PROTEGO® SI/F

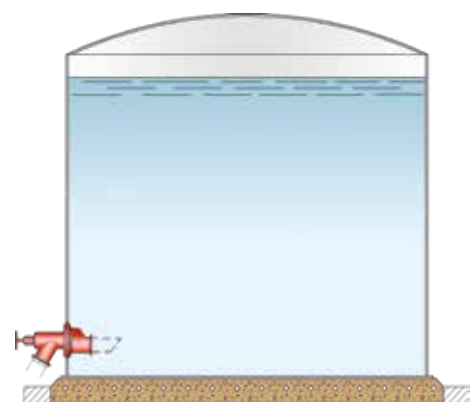

PROTEGO® SI/FA with internal connection nozzle



for safety and environment

[www.protego.com](http://www.protego.com)



**PROTEGO**

*for safety and environment*